

The Hydraulic Quencher Dynamic Vibrations

Leonid Pelevin, Mykola Karpenko

Kyiv National University of Construction and Architecture
Povitroflotskyy prosp., 31, Kyiv, Ukraine, 03680, e-mail: karpenko_knuba@ukr.net

Summary. Carried out a review and analysis of the developed hydraulic system for quenching dynamic oscillations. Made the mathematical model for determining the time delay operation of the hydraulic system of the dynamic quenching of oscillations. Performed a period's calculation of cleavage of the soil and the time delay operation quencher dynamic oscillations from which it is possible in theory to establish the ability of the hydraulic system of dynamic quenching oscillations to operate in time. Developed hydraulic system dynamic quenching oscillations that occur inside the working unit to prevent the transmission of vibrations to the base of the machine. Conducted the analysis of the damper's means and the method of dynamic damping on which developed hydraulic system for quenching dynamic oscillations. Was built mathematical sequence for determination of the time delay operation of the quencher. Parameters allow you to construct experimental model hydraulic system quenching of dynamic oscillations.

Key words: quencher, the dynamic oscillations, hydraulic system, the time lag response, period cleavage soil.

INTRODUCTION

The construction often includes works that cannot be performed by conventional machines. In this case, using a special technique, which is equipped by active action engines and used for ground operations can be consider as a solution.

One of the disadvantages of this special technology – transmission of vibrations from the working body to base machine, accompanied by the premature wearing down of the parts of the basic machine which do not participate in the destruction of the ground.

To solve the problem mentioned above will help amortizable equipment to isolate vibrations from the movement of the working body to the base machine.

Given that the current cushioning devices are not effective enough and demand a construction a new hydraulic system dynamic quenching oscillations and mathematical

model for determination of the one of the main characteristics of the new system, namely: determining the time delay in the operation of the hydraulic system dynamic quenching oscillations for evaluation, timeliness, triggering of on specified dynamic fluctuations.

PURPOSE OF WORK

Based on the results of the analysis of the method of the dynamic analysis and vibration cushioning devices to develop:

- A mathematical model for determining the time delay in the operation of the hydraulic system dynamic quenching oscillations;
- Own hydraulic construction for extinguishing dynamic oscillations that arise inside the working organ for impossible their transmission to the base machine.

THE MAIN MATERIAL

In engineering is often necessary to damp the vibration transmitted to the machine from its working equipment. Basically – it is machines with dynamic (active) working tools. As a result of work, the vibrations can be transmitted to the machine and cause destruction. For impossibility transmit the vibrations from the working body to the base machine used so-called springy elements that are trying to put out vibrations transmitted to the base machine. The main method of vibration damping is called – a method of dynamic vibration damping [3, 4, 5, 15, 19].

The method of dynamic vibration damping is based on the accession to the object's vibration protection additional devices to change its vibration's condition. A work of the dynamic quencher is based on putting out the force transmitted to the object. This dynamic quenching differs from another method of reducing vibration, characterized by imposition of the additional kinematic object linkages, such as fixing some of its points [2, 19].

Changing the base machine a vibrating condition when joining a dynamic quencher can be achieved by the redistribution of vibrational energy from the object to the quencher and in the direction of the increasing energy dissipation fluctuations [13, 20]. The first from mentioned is implemented by changing the system's settings of the object-quencher over the frequencies of the vibration excitation by correcting the elastic-inertial properties of the system. In this case, attachable to the object devices are called the inertial dynamic quenchers. The inertial quencher is used to suppress harmonic mono or narrowband random fluctuations.

During a vibration's load of the wider frequency range the second method is preferred. It is based on increasing dissipative properties of the system by attaching to the object additional specific damping elements. Dynamic quencher dissipative types are called absorbers vibrations [3]. The combined ways of the dynamic quenching using both correction elastic-inertial and dissipative properties of the system are also possible. In such cases

we talk about the dynamic quencher of friction [7, 16].

When implementing dynamic quencher counteraction fluctuations the object carried by reactions that are passed to it attached bodies. For this reason, considerable efforts with limited amplitudes masses adjusted, can be achieved only by large mass (moment of inertia) connected bodies, typically $\approx 5...20\%$ of the reduced mass (moment of inertia) primary system appropriate form of vibrations within the frequency quenching which is performed respectively [3].

Typically, dynamic quencher is used to achieve a local effect: a reduction of the object's vibration in parts where the quencher is fastened. Often it may be associated even with the deterioration of the object's vibration in the other – less appropriate places.

Dynamic quencher can be constructively implemented based on the passive elements (Fig. 1) (masses, springs, shock absorbers, dampers) and the active ones, which have their own power sources.

In the last case, we are talking about the use of the automatic control systems that use electric, hydraulic and pneumatic driven el-

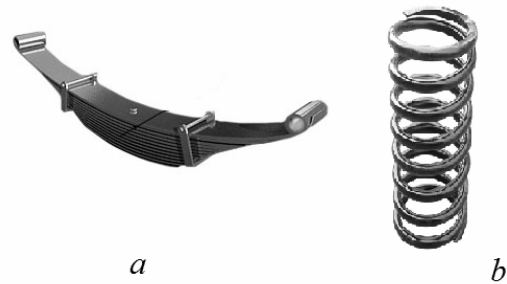

Fig. 1. The overall look of shock absorbing passive elements:

a – spring (of vehicle), *b* – spring

ements. Successful is their combination of passive devices, an example of which is the shock absorber shown in Fig. 2.

The utilization of the active elements expands the possibilities dynamic vibration's suppression, because allows to conduct continuous adjustment of the parameters of dynamic quencher as a function of excitation

acting, and thus perform quenching in conditions of changing vibration loads. A similar result can be achieved sometimes by means of passive devices with nonlinear characteristics.



Fig. 2. General view of the shock absorber

Shock absorber – the device which converts the mechanical energy in the thermal and is used for vibration damping (damping) and shock absorption and bumps acting on the casing (frame). Shock absorbers are used in conjunction with elastic elements: springs(of vehicle) or springs, pillows, etc.

Hydraulic shock absorbers became the most commonly used. In hydraulic shock absorber the resistance force depends on the speed of movement of rod. Working medium – oil. The principle of operation of the shock absorber is based on the reciprocating movement of the piston shock absorber, which through a small hole puts an oil from one chamber to another, converting mechanical energy in the heat energy.

Today, the generally used solutions for vibration damping devices are those which utilize the hydraulic elements. Hydraulic dampers as opposed to friction ones, have the longer duration of work and can demperfering a small oscillation amplitude.

In Fig. 3 is shown the design of the damper, which contains the adjusting screw. This allows to increase the resistance value of the flowing liquid through the channel and thus governed by a calming according to [9, 12, 13].

Nowadays, the most promising is the hydraulic vibration damping system, which is designed based on hydraulic shock absorbers and dampers.

In the design of hydraulic systems blanking dynamic fluctuations must be considered

dynamic characteristics of systems, which, in particular, the transfer speed signals and the total system performance, pressure fluctuations in various points of the system (including hydraulic shocks), sustainability and quality of system transients [1, 11].

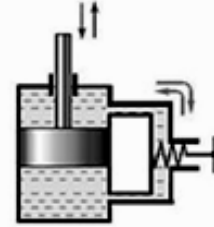

Fig. 3. Liquid dampers adjusting screw

Movement of actuating mechanism always comes with some delay in relation to the input signal. The identification of the delay's amount allows to perform the dynamic system's, the total response time and the need to introduce appropriate units to compensate for the delay calculation, depending on the frequency control signal and set when the corresponding pulses [8, 17, 9].

To perform the system's calculations it is necessary to know the basic system parameters, including the size of pipelines, hydraulic and mechanical resistance properties of the working fluid and hydraulic machines, hydraulic power source characteristics [6].

Total delay time of the system's response can be defined as a first approximation by the formula:

$$t_d = \frac{\Delta V + V_1}{Q_h + 0,5Q_b}, \quad (1)$$

where: ΔV – reduces the volume of liquid in the system by increasing the pressure on the value of Δp , m^3 , V_1 – volume of fluid required to filled-tion of additional volumes in the system, m^3 , Q_b – leak in the system for working pressure, m^3/s , Q_h – the nominal flow rate in the system, m^3/s .

In this case Q_h and V_1 determined from the formula:

$$Q_h = \frac{17,1N_h}{P_h}, \quad (2)$$

where: N_h – hydraulic drive power, kW, P_h – nominal pressure hydraulic system MPa.

The volume of the fluid required to fill the additional volume in the system V_1 , is 5...10% of the total volume of fluid in the hydraulic system V , m³. The total volume of fluid in the hydraulic system is calculated as follows:

$$V = V_c + V_e \quad (3)$$

where: V_e – the amount of hydraulic fluid that is equipped in hydraulic system, m³, V_c – the amount of hydraulic fluid that is in the pipeline hydraulic system Eq. (3), which is calculated by the equation:

$$V_c = \frac{\pi D^2}{4} L, \quad (4)$$

where: L – total length of pipelines, m, D – internal diameter hydraulic of the pipeline, m², calculated by the formula:

$$D = 4,5\sqrt{Q_h/W}, \quad (5)$$

where: W – speed liquid is in the hydraulic system at a prescribed pressure, m/s.

$$V_1 = (0,05...0,1)V. \quad (6)$$

At first approaching the delay operation of the system Eq. (1) we obtain the equation:

$$t_d = \frac{\Delta V + V_1}{Q_h} \cdot \frac{1}{1 - \frac{Q_b}{2Q_h}}. \quad (7)$$

In the view of that:

$$Q_b = K_b P, \quad (8)$$

where: P – operating pressure in the system, MPa, K_b – the coefficient of leakage of liquid, received from the equation:

$$K_b = j \frac{61,2N_h}{P^2}, \quad (9)$$

where: j – coefficient of that changes the units of measurement of l/min in m³/s and 0.278 matter.

In this case, reduce the volume of liquid in the system while increasing pressure on the value of Δp is calculated as follows:

$$\Delta V = \delta S_1 L, \quad (10)$$

where: δ – coefficient of decrease of the liquid, which depends on the operating pressure; S_1 – cross-section inner diameter hydraulic of the pipeline, m².

Moreover, S_1 is calculated as follows:

$$S_1 = \frac{\pi D^2}{4}. \quad (11)$$

In the final order determining equations will get simplified the delay triggering, performance, which will look like:

$$t_d = \frac{\delta S_1 L + V_1}{Q_h - 0,5K_b P}. \quad (12)$$

From dependence is obvious that to reduce the delay's time triggering it is necessary:

1. Working channels and pipelines should be as short and rigid,
2. Volume losses should lowered to a minimum,
3. Pump capacity should be significant.

In general, the performance of the quencher dynamic oscillations is determined for each a particular system, provided that the signal can be transmitted with a specific delay, but performance must be such as not to violate the stability of the all circuit [18].

To achieve the stated conditions, we need to know period the cleavage of soil that need to find the time at which the dynamic working organ ripper makes one complete cycle of the movement T_c [14], and is inversely to the

average oscillation frequency maxima of cutting the soil, and is given by:

$$T_c = \frac{1}{\bar{n}_m} \text{ s}, \quad (13)$$

$$\bar{n}_m = \frac{\bar{n}_0}{0,63\dots 0,87} \text{ 1/s}, \quad (14)$$

where: $\bar{n}_0 = (2,0\dots 2,8) \frac{W_w}{H}$ 1/s – the average oscillation frequency of cutting soil H – loosening depth, m, W_w – speed of the working body.

Determine the dependence of time the delay triggering quencher dynamic fluctuations of hydraulic parameters [2, 19].

Suppose that a dynamic body of work in rocky soil at a depth of $H = 0,3$ m, in which case the rate of dynamic body is

$$W_w = 2 \text{ m/s}.$$

First of all determine the period shearing soil:

$$T_c = \frac{1}{\bar{n}_m} = \frac{1}{15,3} = 0,09 \text{ s}. \quad (15)$$

Determine a relationship Eq. (14) middle frequency oscillation cutting forces:

$$\bar{n}_m = \frac{\bar{n}_0}{0,63\dots 0,87} = \frac{13,3}{0,87} = 15,3 \text{ 1/s}, \quad (16)$$

$$\bar{n}_0 = 2 \cdot \frac{2}{0,3} = 13,3 \text{ 1/s}. \quad (17)$$

Initial data hydraulic system blanking dynamic oscillations: $N_h = 100$ kW, $P_h = 25$ MPa, $P = 30$ MPa, $L = 20$ m, $W = 4.25$ m/s.

Carry out a calculation:

$$Q_h = \frac{17,1 \cdot 100}{25} = 68,1 \text{ m}^3/\text{s}, \quad (18)$$

$$D = 4,5 \cdot \sqrt{68,1/4,25} = 18 \text{ mm}, \quad (19)$$

$$V_{\text{con.}} = \frac{3,14 \cdot 0,018^2}{4} \cdot 20 = 0,0051 \text{ m}^3, \quad (20)$$

$$V_1 = (0,0051 + 0,0549) \cdot 0,1 = 0,006 \text{ m}^3, \quad (21)$$

$$S_1 = \frac{3,14 \cdot 0,018^2}{4} = 0,00026 \text{ m}^2, \quad (22)$$

$$K_b = 0,278 \frac{61,2 \cdot 100}{30^2} = 1,89 \text{ kW/MPa}^2, \quad (23)$$

$$t_d = \frac{30 \cdot 0,00026 \cdot 20 + 0,006}{68,1 - 0,5 \cdot 1,89 \cdot 30} = 0,004 \text{ s}. \quad (24)$$

From the resulting example we can conclude that the system performance satisfies oscillation quenching specified condition of this dynamic organ as triggering delay is less than 15 % of the period shearing soil.

By changing parameters of the hydraulic system dynamic quenching fluctuations – namely the supply hydraulic fluid in the system and reduce fluid volume ratio, and substituting in the present calculation, we plot the dependence of the delay in operation of the hydraulic system dynamic quenching oscillation (speed) of hydraulic fluid supply system (Fig. 4) and from coefficient reduction of fluid (Fig. 5).

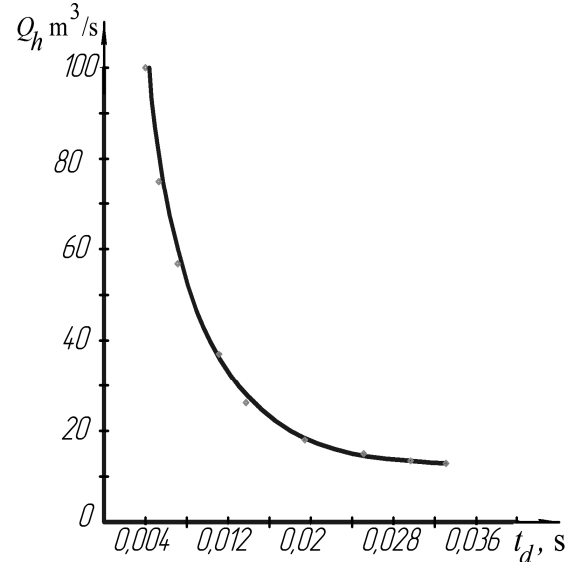

Fig. 4. Graph of the time delay operation hydraulic blanking dynamic fluctuations of supply of hydraulic fluid

The hydraulic quencher dynamic fluctuations was developed to improve the effi-

ciency of dynamic quenching of oscillations, it is based on the use of the system mentioned above.

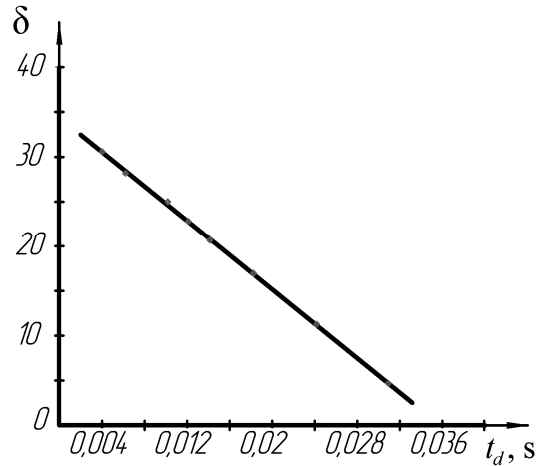

Fig. 5. Graph of the time delay operation hydraulic blanking dynamic fluctuations of coefficient reduce the amount of fluid

Quencher dynamic oscillations (Fig. 6, 7) works as follows [10].

Vibrations that are transmitted from the working body to the base machine blanked with the help dynamic fluctuations quencher 1. At active work oscillatory body rod 3 tries to reproduce vibrational motion in the housing 2. However, when the direction of the vibrational motion is reproduced, for example, left by movement of fluid through the the holes throttled 6 plunger 4, 8 rods blocking valve and plunger valve 11 moving blocking right. Thus blocking rods 8 pressed to valve rods washer 7. Meanwhile blocking plunger valve 11 pressed to plunger 4, blocking throttling holes 6, so that the liquid begins to flow through passage the holes 12, which extinguished the movement of the rod 3 left. Once

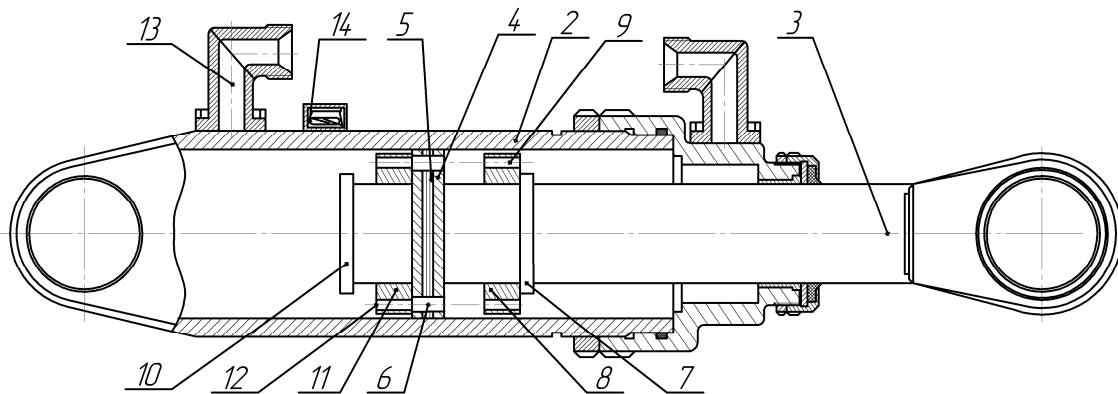

Fig. 6. Quencher dynamic fluctuations

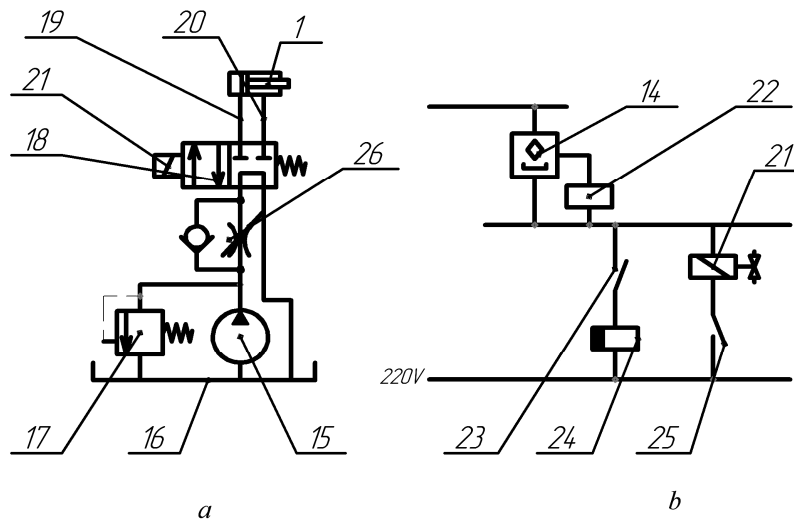

Fig. 7. The hydraulic circuit control quencher dynamic oscillations *a* and electrical circuit control distributor *b*

the plunger 4 reaches the reed switch 14, the magnetic field of the magnet constant step 5 shut reed contacts 14 (Fig. 7, b). The signal will go to detention relay 22, which shut normally open contact 23. He, in turn, turned on the delay relay exclusion 24. After that delay relay exclusion shut 24 contact 25, which starts the electromagnetic control 21. The electromagnetic control 21 toggles the distributor 18 in the left position. Hydraulic pump 15 through a variable orifice with check valve 26, which regulates the supply of hydraulic fluid distributor 18 and pressure line 19 takes an additional portion of the fluid in the plunger cavity quencher dynamic fluctuations 1. Excess fluid flows out of rods quencher dynamic cavity oscillations 1 through the drain line 20 and distributor 18 to a tank of hydraulic fluid 16. When plunger 3 moves to the right by moving the working fluid through the throttling holes 6, 8 rods blocking valve and plunger valve 11 blocking move left. Plunger blocking valve plunger 11 pressed to washer 10 and rods blocking valve 8 pressed to plunger 4 blocking throttling holes 6. As a result, the liquid begins to flow through passage 9 the holes, putting the movement of the rod 3 right. Once the plunger 4 moves away from the reed switch 14 and the magnetic field of the magnet constant step 5 stops to influence the reed switch 14 (reed switch contacts open up 14), the signal ceases to be submitted normally open contact 23. He, in turn, relay switching delay open up exclusion 24. It will work for a while, allowing the hydraulic pump 15 to submit several additional portions of the liquid in the plunger cavity oscillations quencher 1-for-4 plunger removal of reed switch 14. After exclusion of 24 delay relay contact will turn off 25, 21 control the electromagnetic switch distributor 18 in the far right position, then feed additional portion of the liquid to the quencher dynamic fluctuations 1 end. Hydraulic fluid is fed to the quencher through the pipe 13.

Because of the dynamic fluctuations quencher 1 reduced dynamic fluctuations in the base machine, during the working bodies active action.

CONCLUSIONS

1. Based on the analysis of dynamic cushioning devices for vibration in the hydraulic system, the mathematical model of the process of determining the delay's time of their operation, which allows you to design these systems.
2. Based on the values built dependency graphs: time delay operation of the hydraulic system dynamic oscillations on quenching koefitsiyenta reduction of fluid and supply of hydraulic fluid. By changing these parameters the system designed adjustable hydraulic damping system dynamic oscillations.
3. A new design of hydraulic blanking dynamic fluctuations with the ability to change the parameters of the filing.
4. The design provides adjustable vibro base machine from vibrations attachments.

REFERENCES

1. **Bud'ko V. 2003.** Dynamics and regulation hidropnevmosystem. Kyiv, NAU, 64 (in Ukraine).
2. **Cândeia I., Popescu S. 2003.** Theoretical and experimental study on soil vibrators used for the germinal layer preparation. Motrol: kom. Mot. Energ. Roln., OL PAN, vol. 3. (6), 55-62 (in Poland).
3. **Chelomej V.N. 1981.** Vibrations in Technology: Handbook: in 6 volumes. Red. Soviet: (pred.). Moscow, Mashinostroenie, Vol. 6, 456 (in Russian).
4. **Emtsev B. 1987.** Technical hydromechanics.: M.: Mashinostroenie, 439 (in Russian).
5. **Gavrilenko B. Minin V. 1958.** Hydraulic drive. Moscow, Mashinostroenie, 240 (in Russian).
6. **Gijom M. 1964.** Investigation and calculation of hydraulic systems. Moscow, Mashinostroenie, 387 (in Russian).
7. **Korobochkin B. 1976.** dynamics of hydraulic machines. Moscow, Mashinostroenie, 240 (in Russian).
8. **Lewis E., Sterh H. 1966.** Hydraulic control system. Moscow, Mashinostroenie, 407 (in Russian).
9. **Nagorniy V., Denisov A. 1991.** Devices of automation and hydro pneumatic. Moscow, Mashinostroenie, 367 (in Russian).

10. **Patent** Ukraine № 90197 from May 12.2014 (in Ukraine).
11. **Popov D. 1987.** Dynamics and regulation of hydraulic and pneumatic systems. Moscow, Mashinostroenie, 464 (in Russian).
12. **Schokdemper. 2014** Available at: <http://nl.wikipedia.org/wiki/Schokdemper>, accessed 20 Jul. 2014 (in Nederlands).
13. **Shorin V. 1980.** Elimination of fluctuations in air pipes. Moscow, Mashinostroenie, 156 (in Russian).
14. **Vetrov Ju., Vlasov V. 1995.** Machines for excavation. Sample calculation: Teach. user. Kyiv, ISDO, 304 (in Russian).
15. **Vilde A., Cesnieks S., Rucins A. 2004.** Minimisation of Soil Tillage. Motrol: kom. Mot. Energ. Roln., OL PAN, vol. 4. (30), 237-243 (in Poland).
16. **Vilde A., Rucins A. 2004.** The Impact of Soil Physical and Mechanical Properties on Draft Resistance of Ploughs. Motrol: kom. Mot. Energ. Roln., OL PAN, vol. 4. (31), 243-249 (in Poland).
17. **Vilde A., Tanaś W. 2005.** Determination of the soilfriction coefficient and specific adhesion. Motrol: kom. Mot. Energ. Roln., OL PAN, vol. 5. (24), 212-217 (in Poland).
18. **Walusiak S., Dziubiński M., Pietrzyk W. 2005.** An analysis of hydraulic braking system reliability. Motrol: kom. Mot. Energ. Roln., OL PAN, vol. 5. (25), 217-226 (in Poland).
19. **Zakharchuk B., Telushkin V. 1987.** Bulldozer and rippers. Moscow, Mashinostroenie, 240 (in Russian).
20. **Zipkin Ya. 1977.** Foundations of the theory of automatic systems. Moscow, Mashinostroenie, 560 (in Russian).

ГИДРАВЛИЧЕСКИЙ ГАСИТЕЛЬ ДИНАМИЧЕСКИХ КОЛЕБАНИЯХ

Аннотация. Проведен обзор и анализ существующих амортизирующих устройств. Рассмотрен метод динамического гашения колебаний. Составлена математическая модель определения времени запаздывания срабатывания гидроавтоматической системы гашения динамических колебаний, значение которого позволяет создавать гидроавтоматические системы гашения колебаний вовремя реагирующих на динамические внешние возмущения. Проведен расчет периода скальвания грунта при работе рыхлителя и времени запаздывания срабатывания гасителя динамических колебаний, на основе которых устанавливается способность гидроавтоматической системы гашения динамических колебаний вовремя срабатывать обеспечивая предотвращение передачи колебаний к базовой машине. Разработана гидроавтоматическая система гашения динамических колебаний, возникающих на рабочем органе, для предотвращения передачи этих колебаний к базовой машине.

Ключевые слова: гаситель, динамические колебания, гидроавтоматическая система, время запаздывания срабатывания, период скальвания грунта.