

PAPER • OPEN ACCESS

Radiation protective properties of fine-grained concretes and their radiation resistance

To cite this article: D V Anopko *et al* 2020 *IOP Conf. Ser.: Mater. Sci. Eng.* **907** 012031

View the [article online](#) for updates and enhancements.

Radiation protective properties of fine-grained concretes and their radiation resistance

D V Anopko, O A Honchar, M O Kochevykh and L O Kushnierova

Department of Building Materials, Kyiv National University of Construction and Architecture,
Povitroflotsky Avenue 31, 03680, Kyiv, Ukraine

anopko.dv @knuba.edu.ua

Abstract. Studies have shown that the thickness of the half layer of the gamma radiation flux attenuation with $E = 662$ keV is 3,5-5,2 cm (depending on the concrete density average) and for a neutron flux with $E = 2,5$ MeV is 5-6 cm. The radiation resistance of concrete under the influence of gamma radiation large doses, their activity and radionuclide composition after irradiation with neutrons was investigated. To study the behaviour of concrete under the influence of gamma radiation, two series of samples were made. One series was the control, and the second was exposed to gamma radiation. The temperature of the samples during testing did not exceed 40 °C, the dose of gamma radiation was 10^9 rad. Its value corresponds to the dose that concrete can receive when it comes into contact with highly radioactive wastes from the “Shelter” facility for 300 years. The characteristic of an industrial gamma-ray plant is radiation energy of 1,25 MeV and a dose rate of 2 Mrad/h. Using this setup allows you to reach a dose of 10^9 rad in less than a month, and 10^8 rad in 4 - 5 days. Concrete that reached the age of 28 days and stored under normal conditions was exposed to gamma radiation. Analysing the obtained data of physical and mechanical tests of radiation-protective compositions, it can be noted that large doses of gamma radiation practically do not affect the strength of the developed material.

1. Introduction

Many years of world experience in the selection of materials for radiation protection shows that concrete is the main material. It can combine heavy components to protect against gamma radiation and light components to absorb neutron fluxes. This fact, as well as manufacturability, low price and the possibility of using local materials, have determined the widespread use of concrete for protection against radioactive radiation.

The nature of the interaction of γ - and neutron radiation with concrete is different. Electromagnetic γ -radiation can interact with electrons of an atom, nuclear particles (nucleons), with an electric field that surrounds charged particles (nuclei and electrons), and with a meson field that surrounds nucleons [1-3]. Any of these types of interaction of γ -quanta can lead to their complete absorption, elastic or inelastic scattering.

As a result of the interaction of photons with matter, one part of their energy is converted into the kinetic energy of charged particles, and the second part is converted into the energy of secondary photon radiation. The probability of the interaction of γ -radiation with a substance increases with its density, with an increase in the atomic number; therefore, it is advisable to use denser and heavier materials to absorb it [1-4].



The energy perceived by an atom from a neutron that bombards it is expended on its displacement, excitation or ionization. As a result, it changes the material initial microstructure. Local changes (defects) in the crystal lattice and microstructure of the material, which were formed under the influence of irradiation, lead to a profound change in the crystal, molecular and supramolecular structure. This is accompanied by a change in all the properties of the material and is the reason for the decrease in its strength and durability.

2. Materials and methods of research

Radiation-protective properties to the action of γ -radiation and neutrons were determined by comparing the intensity of flows through the material under study and the standard. Concrete plates with a size of $100 \times 100 \times 15$ mm were used as samples. The ^{137}Cs isotope was used as a γ -radiation source, the spectrum of which is predominantly a line with the energy of $E = 662$ keV. The diameter of the radiation source is 6 mm and the thickness is 8 mm. An MKS-01R radiometer with a BDKB-01R detector was used to study the γ -radiation dose rate. A ^{252}Cf neutron source with average neutron energy of $E = 2.5$ MeV was used to study the radiation-protective properties of concrete in a neutron field. An MKS-01R radiometer with a BDKN-03 detector was used to record the intensity of fast and intermediate neutrons.

Concrete cubes of $20 \times 20 \times 20$ mm in size were used to study the formation of secondary γ -radiation with an energy of up to 7,7 MeV. Samples were irradiated in the active zone of the WWRM nuclear reactor in a "wet" channel with the flux density of $5,1 \cdot 10^{13}$ n/cm² for 275 hours. The temperature of the samples did not exceed 50 °C. During the test the flux density was $5,05 \cdot 10^{19}$ n/cm².

To assess the radiation resistance of the composites, the samples were subjected to long-term γ -radiation at the Belgorod-Dniester OJSC "Hemoplast" with an industrial certified γ -installation for sterilizing products with emission energy of 1,25 MeV and a dose rate of 2 Mrad/h. The temperature of the samples did not exceed 40 °C during the test. The radiation dose of concrete received from γ -radiation was received 10^9 rad. Its value corresponds to the dose that concrete can receive when it comes into contact with highly radioactive waste from the Chernobyl sarcophagus over 300 years. The radiation resistance of concrete was evaluated by reducing the tensile strength in bending and compressive strength on samples with dimensions of $40 \times 40 \times 160$ mm.

3. Research results

3.1. Study of radiation-protective concrete properties from the γ -radiation action. The research was conducted at the Scientific Center of the Institute of Nuclear Research of the National Academy of Sciences of Ukraine. The geometry of the experiments is shown in Figure 1.

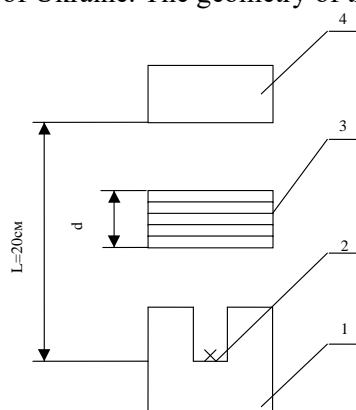

Figure 1. The geometry of the samples and equipment arrangement: 1 - container; 2 - γ -radiation source; 3 - test samples; 4 - detector.

To characterize the degree of absorption of ionizing radiation, such indicators were used [1]:

1. Half-value thickness (HVT) - is the thickness of the protective material layer necessary to halve the radiation intensity.

2. Relaxation length - the thickness of the material layer, which reduces the flux density of particles or photons (quanta) by e times (2,73).

3. Linear attenuation coefficient μ (cm^{-1}) - is a function of the photon radiation energy and the substance type: $\mu = d\varphi_{\omega} / (\varphi_{\omega} \cdot dx)$. It characterizes the relative change in the photon radiation energy flux density $d\varphi_{\omega} / \varphi_{\omega}$ when passing through a layer of matter at $dx = 1$.

4. Mass Attenuation coefficient μ_n (cm^2/g) - the ratio of the linear attenuation coefficient μ to the density of the substance ρ (g/cm^3) depends on the atomic weight of the element: $\mu_n = \mu / \rho$.

The compositions of the samples are given in the table 1.

Table 1. The average density and composition of radiation-protective concrete.

№	The composition, mass%	Ratio binder / aggregate	Average density, kg/m^3
1	Modified binder - 75 Dispersed iron (0,08-0,16MM) - 25	3:1	2350
2	Modified binder - 65 Dispersed iron (0,08-0,16MM) - 35	2:1	2520
3	Modified binder - 50 Dispersed iron (0,08-0,16MM) - 50	1:1	2860
4	Modified binder - 35 Dispersed iron (0,08-0,16MM) - 65	1:2	3640
5	Modified binder - 35 Dispersed iron (0,8-2,0 MM) - 65	1:2	3900
6	Modified binder - 25 Dispersed iron (0,8-2,0 MM) - 75	1:3	5130

The distance between the γ -radiation source and the detector was constant and equal to 20 cm. In studies, the dose rate I_0 was first measured at a distance of 20 cm (when the studied samples are absent between the detector and the radiation source). The dose rate was $I_0 = 24,2$ mSv/h. One, then two, three, four and five plates of each series were installed in series' first. The dose rate was measured for each thickness obtained. For samples of each thickness, 6 measurements were carried out at an exposure of 10 C. Based on the measurement results, the average power value for each thickness was found. The measurement results are shown in table 2.

Table 2. The results of measurements of radiation protective properties of concrete in the field of γ -radiation.

The concrete composition according to the table 1	Linear attenuation coefficient, μ , sm^{-1}	Half-value thickness, cm	Radiation Power Relaxation Length, cm	Mass Attenuation coefficient μ_n , cm^2/g
1	0,1276	5,43	7,84	0,043
2	0,1317	5,26	7,59	0,045
3	0,1320	5,25	7,58	0,043
4	0,1320	5,25	7,58	0,042
5	0,1558	4,45	6,42	0,040
6	0,2167	3,20	4,61	0,042

The measurement results showed that the attenuation of the radiation dose rate for the chosen experiment geometry for the studied series of samples is well described by the exponential law [1]:

$$I = I_0 e^{-\mu X} \tag{1}$$

I – the dose rate at a distance of 20 cm when the studied samples are between the detector and the radiation source; μ – linear attenuation coefficient (cm^{-1}); X – thickness of samples, cm.

The attenuation of the γ -radiation dose rate is also confirmed by the fact that the dependence $\ln[I_0/I(X)]$ is well described by a linear function

$$B(X) = \mu(X) \tag{2}$$

For example, Figure 2 shows the dependence of $\ln[I_0/I(X)]$ on thickness x for concrete compositions 5 and 6. It can be seen from this figure that the experimental values of $\ln[I_0/I(X)]$ are well described by line dependence $B(X) = \mu X$. The slope of the straight lines for concrete compounds 5 and 6 is different. The tangent of their slope determines the linear attenuation coefficient μ .

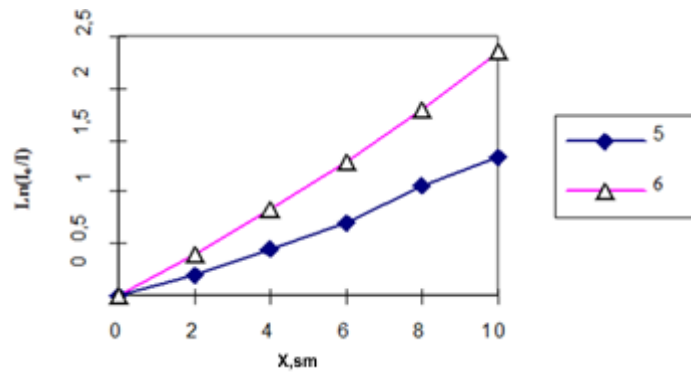

Figure 2. The dependence of $\ln(I_0/I)$ on the thickness of the sample.
Legend: 5, 6 - concrete composition numbers.

The linear attenuation coefficient μ for each series of concrete compositions was calculated by the formula $[I_0/I(X)]$

$$\mu = \frac{\sum_{i=1}^5 Y_i X_i}{\sum_{i=1}^5 X_i X_i}, \quad Y_i = \ln[I_0/I(X)] \tag{3}$$

In the calculations according to formula (3), the average value of the plate thickness along its diagonal was used. The calculations showed that concretes of compositions 5 and 6 have the highest linear attenuation coefficient of γ -radiation. This is due to higher rates of their density. The data obtained correspond to known patterns [1, 2]. From the data obtained it follows that concretes of 5 and 6 compositions are most effective as radiation protective materials from the action of γ - radiation.

3.2. The study of radiation protective concrete properties under the neutron radiation influence.

We studied the attenuation of the intensity of the flux of fast and intermediate neutrons as they pass through a set of concrete plates in an amount of one to five pieces for each composition. The neutron source was in a paraffin container at a depth of 10 cm from the surface of the container opening. The distance between the detector surface and the hole was remained unchanged (10 cm). The thickness of the concrete between the detector and the radiation source was increased by setting concrete plates in the gap between the detector and the radiation source. The results showed that for the chosen geometry

of the experiments, the dependence of the neutron flux intensity on the thickness of the shield is well described by the exponential dependence [1]:

$$\varphi = \varphi_0 e^{-X/L} \tag{4}$$

φ_0 – the intensity of the flow of fast and intermediate neutrons without plates of concrete between the neutron source and the detector; L - the length of neutron relaxation in the medium, cm; X - thickness of a set of plates of concrete, cm.

To obtain the necessary statistics for each thickness, we measured the neutron flux intensity 6 times with an exposure time of 10s. Then found their average value. To calculate L , the average value of the plate thickness along its diagonal was used. In the experiments, $\varphi_0 = 62,4$ n/cm² s. The experimental values for different series of concrete are given in table 3.

Since the dependence $\ln[\varphi_0/\varphi(X)]$ is well described by the linear function $B = X/L$, using the least-squares method, the relaxation length L can be calculated by the formula:

$$L = \frac{\sum_{i=1}^5 (X_i X_i)}{\sum_{i=1}^5 Y_i X_i} \tag{5}$$

Studies of radiation-protective properties of the proposed concrete formulations have shown that they have high protective indicators. Thus, the Half-value thickness for neutron radiation is 4,7-6,2 cm. The relaxation length of the neutron radiation power for fast and intermediate neutrons in the studied concrete samples is within the measurement accuracy and weakly depends on the composition.

Table 3. The results of measurements of radiation protective properties of concrete in a neutron radiation field.

The composition of concrete according to the table 1	Half-value thickness, cm	The relaxation length of the power of neutron radiation, cm
1	4,64	6,69
2	5,20	7,46
3	6,17	8,91
4	5,07	7,32
5	5,58	8,05
6	5,01	7,23

Thus, the tested concrete compositions according to the results of studies shown in tables 2 and 3, effectively protect against gamma - and neutron radiation. This is evidenced by the insignificant thicknesses of the layers of half-value thickness of neutron and gamma radiation.

3.3. Study of the radionuclide composition and activity of radiation-protective concrete.

From literary sources, it is known [2, 3] that during irradiation of heavy concrete based on metal aggregate under the influence of neutron radiation, secondary γ -radiation with an energy of up to 7,7 MeV is formed. Therefore, it is necessary to study the radionuclide composition and activity of radiation-ionizing fine-grained concrete after their irradiation with a neutron flux.

Studies were performed on concrete compositions 3, 4 (table 1). For this, cubic samples of 20×20×20 mm in size were made, three samples of each composition. After radiation, for the decomposition of short-lived radionuclides, concrete samples were kept in “hot chambers” for 168 hours. After that, the samples were removed from special ampoules and their radionuclide composition and activity were examined. The exposure dose rate of γ -radiation was determined at a distance of 10 cm from the samples. The measurement was performed using a germanium-lithium

gamma spectrometer with a NUC 8092 analyzer system and subsequent processing of gamma spectra with a special AK program. The measurement results with an error of $\pm 10\%$ are shown in table 4.

As follows from the data given in table 4, the greatest contribution to the activity of concrete samples is made by the radionuclides ^{51}Cr and ^{59}Fe , which are formed in the reactor core from the reaction (n, γ) . For example, a ^{51}Cr radionuclide ($T_{1/2} = 27,7$ days) is converted to ^{51}V via electron capture. This transformation is accompanied by the emission of γ -quanta with energy of 0,320 MeV, x-ray radiation and electron radiation. Receipt scheme $^{51}\text{Cr}: ^{50}\text{Cr} + (n, \gamma) \rightarrow ^{51}\text{Cr} \rightarrow ^{51}\text{V}$.

The calculated specific activity of ^{51}Cr , which is formed in the reactor core at a flux density of $5,1 \cdot 10^3$ n/cm², per 1 g of natural Cr is $1,06 \cdot 10^{11}$ Bq/g. This is 3-4 orders of magnitude more than concrete.

A similar pattern of the formation of the ^{59}Fe radionuclide, which is formed from natural ^{58}Fe by (n, γ) reaction: $^{58}\text{Fe} + (n, \gamma) \rightarrow ^{59}\text{Fe} \rightarrow ^{59}\text{Co}$.

The specific activity of ^{59}Fe is $1,2 \cdot 10^{10}$ Bq/g, which is 3 orders of magnitude more than that of concrete.

Table 4. Radionuclide composition and activity of concrete

The composition according to table 1	Concrete sample	Radionuclide	Half-life, days	Specific activity Bq/g (Ki/g)	Exposure dose rate γ -radiation, mR/h
3	1	^{51}Cr	27,7	$1,07 \cdot 10^7 (2,88 \cdot 10^{-3})$	8,0
		^{54}Mn	312	$3,95 \cdot 10^6 (1,06 \cdot 10^{-4})$	
		^{59}Fe	44,6	$8,99 \cdot 10^7 (2,43 \cdot 10^{-3})$	
		^{60}Co	5,272 (years)	$6,79 \cdot 10^5 (1,83 \cdot 10^{-5})$	
	2	^{51}Cr	27,7	$1,02 \cdot 10^8 (2,76 \cdot 10^{-3})$	7,0
		^{54}Mn	312	$3,85 \cdot 10^6 (1,04 \cdot 10^{-4})$	
		^{59}Fe	44,6	$8,89 \cdot 10^7 (2,40 \cdot 10^{-3})$	
		^{60}Co	5,272 (years)	$6,72 \cdot 10^5 (1,82 \cdot 10^{-5})$	
	3	^{51}Cr	27,7	$1,05 \cdot 10^8 (2,8 \cdot 10^{-3})$	9,0
		^{54}Mn	312	$3,9 \cdot 10^6 (1,05 \cdot 10^{-4})$	
		^{59}Fe	44,6	$8,96 \cdot 10^7 (2,42 \cdot 10^{-3})$	
		^{60}Co	5,272 (years)	$6,77 \cdot 10^5 (1,82 \cdot 10^{-3})$	
4	1	^{51}Cr	27,7	$1,48 \cdot 10^8 (4,1 \cdot 10^{-3})$	12,0
		^{54}Mn	312	$4,03 \cdot 10^6 (1,09 \cdot 10^{-4})$	
		^{59}Fe	44,6	$8,45 \cdot 10^7 (2,28 \cdot 10^{-3})$	
		^{60}Co	5,272 (years)	$6,75 \cdot 10^5 (1,82 \cdot 10^{-3})$	
	2	^{51}Cr	27,7	$1,46 \cdot 10^8 (3,93 \cdot 10^{-3})$	12,3
		^{54}Mn	312	$4,0 \cdot 10^6 (1,08 \cdot 10^{-4})$	
		^{59}Fe	44,6	$8,41 \cdot 10^7 (2,27 \cdot 10^{-3})$	
		^{60}Co	5,272 (years)	$6,82 \cdot 10^5 (1,82 \cdot 10^{-3})$	
	3	^{51}Cr	27,7	$1,4 \cdot 10^8 (3,78 \cdot 10^{-3})$	12,0
		^{54}Mn	312	$3,91 \cdot 10^6 (1,06 \cdot 10^{-4})$	
		^{59}Fe	44,6	$8,26 \cdot 10^7 (2,23 \cdot 10^{-3})$	
		^{60}Co	5,272 (years)	$6,79 \cdot 10^5 (1,82 \cdot 10^{-3})$	

3.4. Study of the radiation resistance of concrete in the gamma radiation field

The durability of radiation-protective concrete is determined not only by their high ability to absorb ionizing radiation, but also possess high radiation resistance in the field of ionizing radiation. Radiation resistance is the ability of a material to maintain its properties after irradiation [2, 3]. From literary sources, it is known [3, 4] that concretes based on Portland cement and based on slag-alkali cement during prolonged exposure to γ -rays have a fairly high radiation resistance. The radiation resistance of

the studied non-shrinking concrete, which contains a significant amount of highly basic calcium hydrated sulfoferrite with prolonged exposure to γ -radiation, is not known. Therefore, special studies were conducted on the behavior of these composites under the action of ionizing radiation.

The study of the influence of prolonged exposure to γ -radiation on the properties of the material was carried out on the concrete, the compositions of which are given in table 1.

Two groups of concrete samples were used: one - was not exposed to γ -radiation, the second - was exposed to γ -radiation.

Concrete, which reached the age of 28 days and stored under normal conditions, was exposed to γ radiation. This setup allows getting the required dose in a short period of time - 10^9 rad less than a month, and 10^8 rad - in 4-5 days. This makes it possible to study the structure of the material without taking into account the significant influence of cement stone hydration processes on it.

The impact on the material of such a significant energy impulse violates its thermodynamic equilibrium. This creates the conditions for the appearance of significant fluctuation processes in it, directed at the formation of structure regularity violations. To reduce the intensity of fluctuations, it is advisable to create composites with a minimum value of their anisotropy of properties, which is controlled by the size of the aggregate and the degree of cement expansion [5]. This was realized during the creation of these composites and described in [6, 7]. The results of mechanical and physico-mechanical tests of concrete are given in tables 5. Tests on the radiation resistance of concrete under the influence of gamma radiation showed that they do not lose compressive strength when absorbed at a dose of 10^8 and 10^9 rad (table 5). These results are consistent with known data [2, 4].

The results obtained indicate that, as a result of radiation, the compressive strength of the samples not only did not decrease but also increased. This can be explained by the fact that the intensification of the concrete structure formation process by the influence of gamma-ray, and the resulting structural disturbances, are directed at increasing their compressive strength.

The emerging structural disturbances can be characterized as self-organizing, which contributes to an increase in the strength of the material [5].

Table 5. Change in compressive strength and bending strength of concrete under prolonged exposure to gamma radiation

The composition of concrete according to the table 1	Compressive strength, MPa				Bending strength, MPa			
	Control samples, age, days		Samples that have absorbed the dose, rad		Control samples, age, days		Samples that have absorbed the dose, rad	
	28	56	10^8 , age 32 days	10^9 age 56 days	28	56	10^8 , age 32 days	10^9 age 56 days
1	55	55	55	56	1,9	2,0	1,5	2,0
2	51	52	51	52	1,9	2,1	2,0	2,4
3	51	51	52	52	1,6	1,85	1,85	2,3
4	53	54	54	55	1,2	1,3	1,3	1,4
5	48	49	48	49	1,2	1,2	1,2	1,2
6	64	66	67	70	0,93	0,94	1,00	0,76

Analyzing the data obtained, it can be noted that using the proposed methods for regulating the composition and technology of fine-grained concrete (changing the phase composition of the binder hydration products towards the formation of highly basic hydrosulfoferrites and calcium sulfoaluminoferrites due to the introduction of silica fume, iron oxide additives, and metallic iron, using aggregates of different dispersion) managing the formation of self-organizing structures in cement and obtaining a high-quality artificial stone.

So, gamma irradiation of samples with a dose of 10^8 rad leads to a transformation of the structure of cement and concrete based on it (compositions 1, 2, table 5), which is accompanied by a temporary

decrease in the strength during bending of concrete. Further irradiation with a simultaneous restructuring of the structure causes an increase in the strength of the material during bending. The introduction of the proposed addition of silica fume with iron oxide and pure metal eliminates the negative effect of gamma radiation on the strength of concrete; there is even an increase in bending strength over the entire radiation interval.

It should also be noted that the dispersion and amount of aggregate affect the resistance of concrete to gamma radiation. The use of dispersed aggregate provides an increase in the strength of concrete in bending (composition 4, table 5). An increase in the dispersion of the aggregate (0,8 - 2,0 mm) is accompanied by a decrease in the growth of concrete strength during irradiation (composition 5, table 5). With an increase in the amount of aggregate (composition 6, table 5), there is a significant increase in compressive strength and a slight decrease in concrete strength in bending after exposure to gamma radiation with a dose of 10^9 rad, which does not exceed allowable values. The obtained values of concrete bending strength will increase in time as a result of the binder hydration process, and the compressive strength of concrete will also increase after the action of γ -radiation.

4. Conclusion

The developed composites have half-value for the γ -radiation of the ^{137}Cs isotope with energy $E = 662 \text{ keV} - 3,20\dots 5,29 \text{ cm}$, and for neutron radiation ^{252}Cf with energy $E = 2,5 \text{ MeV} - 5,01\dots 6,17 \text{ cm}$. The developed concrete compositions have a small activity (3-4 orders of magnitude lower) compared to natural chromium and iron if the latter are exposed to neutron radiation. The influence on the material of such a significant energy impact removes it from thermodynamic equilibrium, which creates the conditions for the occurrence of significant fluctuation processes in it, aimed at creating violations of the regularity of the structure. To reduce the intensity of fluctuations, it is advisable to create composites with a minimum value of the anisotropy of their properties, which in the developed materials is controlled by the dispersion of the aggregate and the degree of expansion of cement. This confirms the promise of using the proposed fine-grained concrete as radiation-protective materials.

It was established that the studied composites have significant radiation resistance in the fields of gamma radiation at a dose of up to 1000 Mrad. They are characterized by an increase in compressive strength and stable values of tensile strength in bending. Based on the data obtained, it is possible to develop concrete compositions for industrial production and use. It is also of interest to study the properties of these composites at the meso- and microlevels after prolonged irradiation with neutrons and gamma rays, and in the future, use of the theoretical method for modeling the transfer of neutron flux in various media [8, 9]. Simulation of the passage of neutrons through concrete layers of various thicknesses, in particular, a neutron flux with an energy of up to 14 MeV, will allow one to calculate the protective properties of the studied composites for plasma focus units, thermonuclear reactors, and fast neutron reactors [10 - 11], since experimental studies with sources of such high power is associated with a number of technical problems.

References

- [1] Egorov Yu A 1983 *Fundamentals of radiation safety of nuclear power plants* (Moscow: Energoatomizdat) vol **2** p 330
- [2] Dubrovskiy V B 1977 *Radiation resistance of building materials* (Moscow: Stroyizdat) p 278
- [3] Dubrovskiy V B and Ablevich Z 1983 *Construction Materials. Building materials and structures for protection against ionizing radiation* (Moscow: Stroyizdat) p 240
- [4] Petrova T M, Komohov P G et al 1997 Radiation-resistant concrete based on slag-alkali binders *Cement* vol **1** pp 33-35
- [5] Sheynich L A and Pushkareva E K 2009 *Self-organization processes of the structure of building composites* (K: Gamma-print) p 153
- [6] Sheynich L A and Anopko D V 2011 *Radiation-protective non-shrinking fine-grained concrete on cast-iron aggregates* (K: Gamma-print) p 198

- [7] Anopko D V, Gonchar O A, Kobylyanskiy I Z 2019 Composite radiation protective cement with enhanced thermal and crack resistance *Scientific Bulletin of Civil Engineering* (Kharkiv: KhNUBA) vol **98** pp 231-240
- [8] Wagner J C, Peplow D E, Mosher S W, Evans T M 2011 Review of Hybrid Deterministic/Monte Carlo Radiation Transport Methods, Codes, and Applications at Oak Ridge National Laboratory *Progress in Nuclear Science and Technology* vol **2** pp 808-814
- [9] Romanenko I M, Golyuk M I, Nosovskiy A V, Gulik V 2018 Investigation of a New Composite Material Based on Ultra Heavy Concrete and Basalt Fiber for Radiation Protection from Gamma Radiation *Yaderna ta radiatsiyyna bezpeka* vol 1(**77**) pp 52-58
- [10] Gulik V and Tkaczyk A H 2014 Cost optimization of ADS design: Comparative study of externally driven heterogeneous and homogeneous two-zone subcritical reactor systems *Nuclear Engineering and Design* Issue **270** pp 133-142
- [11] Sharifi Sh, Bagheri R, Shirmardi S P 2013 Comparison of shielding properties for ordinary, barite, serpentine and steel-magnetite concretes using MCNP-4C code and available experimental results *Annals of Nuclear Energy* Issue **53** pp 529-534